



# PC03

Healthy Climate®

PureAir™ Air Purification System - 60 Hz

## RESIDENTIAL PRODUCT SPECIFICATIONS

Bulletin No. 210730  
April 2023  
Supersedes August 2021



### MODEL NUMBER IDENTIFICATION

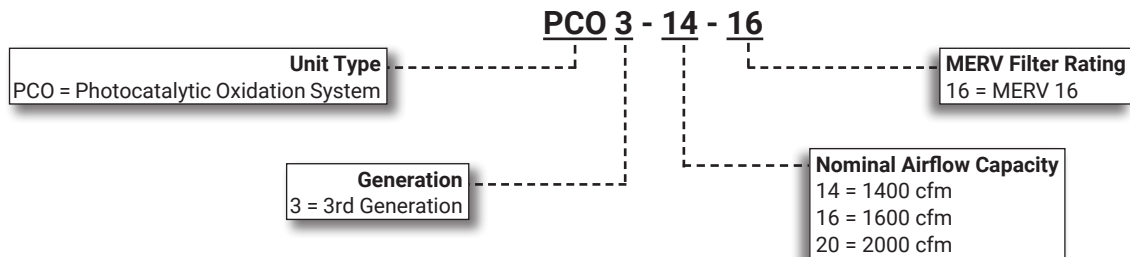

## FEATURES HIGHLIGHTS

1. MERV 16 Carbon Clean 16® Media Air Filter
2. UVA Lamp
3. PureAir™ Cartridge
4. Heavy Gauge Steel Cabinet
5. Front Panel Access
6. Control Box Assembly

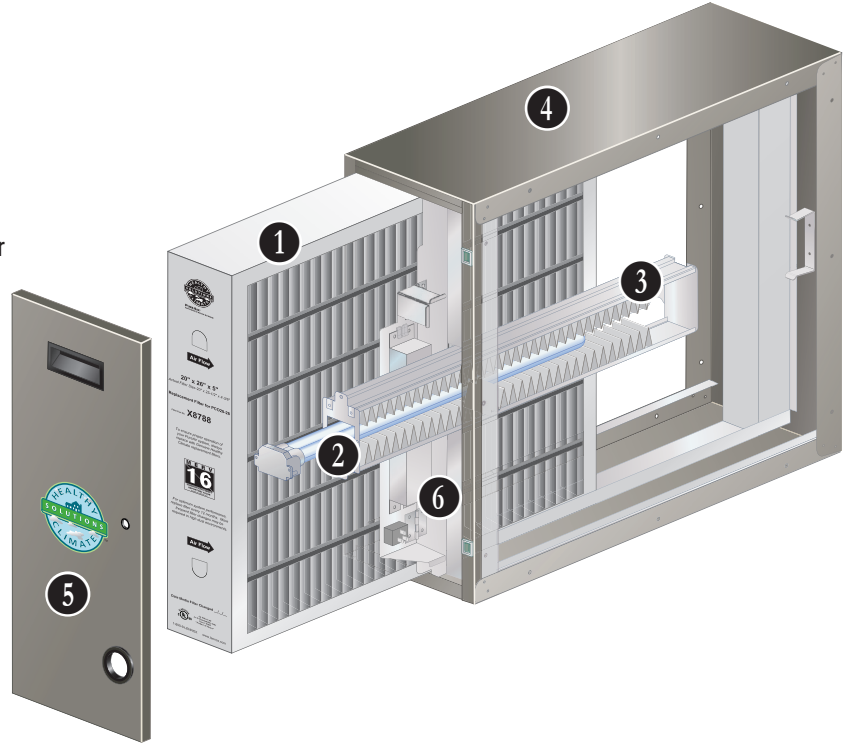

## CONTENTS

Air Resistance . . . . .	5
Approvals And Warranty . . . . .	2
Cabinet Match-Ups - Pco3 With Furnace / Air Handler . . . . .	6
Dimensions . . . . .	5
Features . . . . .	3
Features Highlights . . . . .	2
Minimum Filter Efficiency . . . . .	5
Optional Accessories - Order Separately . . . . .	4
Specifications . . . . .	4

## APPROVALS AND WARRANTY

### APPROVALS

- ETL safety listing report 3061144A
- Conforms to UL STD 1598
- Certified to CSA STD C22.2 no. 250.0

### WARRANTY

- All covered components:
  - Limited five years warranty in residential applications
  - Limited one-year in non-residential applications

**NOTE** - The UVA Lamp / PureAir Cartridge, and pleated MERV 16 Carbon Clean 16® media filters are routine maintenance items and are not covered under the warranty.

**NOTE** - Refer to Lennox® Basic Limited Warranty at [www.Lennox.com](http://www.Lennox.com) for additional details.

## FEATURES

### OPERATION

- Return air first passes through the MERV 16 Carbon Clean 16® media filter
- The filter removes more than 95% of the particles and bioaerosols (dander, pollen, bacteria, molds, spores, etc.) as they flow through the PCO3
- The filtered air then passes through the UVA Lamp / PureAir Cartridge
- The UVA lamp activates the catalyst on the cartridge that captures and destroys odors and chemical vapors as they flow through the system
- The adsorbed pollutants (accumulated gases, liquids, or solids) on the surface of the catalyst are oxidized to carbon dioxide and water
- Rather than just absorbing gaseous pollutants (as in carbon systems), the PCO3 provides a reduction of absolute toxicity
- Contaminants are destroyed rather than transferred
- The PureAir Cartridge is self-cleaning with respect to the organic material adsorbed on the catalyst surface
- No toxic chemicals are used in the PCO3

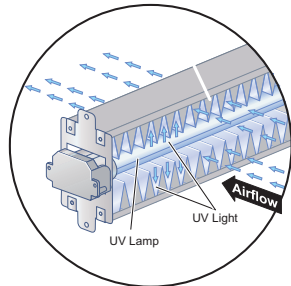

### APPLICATIONS

- The PureAir™ Air Purification System combines multiple air purification technologies into a single, state-of-the-art, air purifier
- The system's primary function is to improve the indoor air quality by:
  - **Filtration** - The MERV 16 Carbon Clean 16® media filter captures more than 95% of particles 0.3 microns and larger and more than 90% of particles 0.01 microns and larger
  - **Photocatalytic Oxidation** - The UVA lamp activates the photocatalyst on the PureAir Cartridge that captures and destroys odors and chemical vapors as they flow through the PCO3
- The system reduces the toxicity of the treated air stream
- The PCO3 is a multi-position unit that can be installed in the return air side of all types of HVAC whole-house systems
- The unit easily adapts to upflow, downflow or horizontal unit applications
- No ozone is produced by the PCO3; in fact, ozone is reduced by the PCO3
- Only requires annual maintenance

### INSTALLATION CONSIDERATIONS

- The PCO3 must be installed in the return air duct upstream of the supply air blower
- Allow a 30 in. service clearance in front of the access door
- The control box, pleated filter and the PureAir UVA Lamp Cartridge must be removable

- The PCO3 should be installed in a horizontal position with the access panel facing to the front or rear
- The PCO3 must be connected to either a 120V or 230V power receptacle
- If 230V power supply is used, an optional 230V power cord must be ordered separately
- See Optional Accessories table
- Unit must be powered continuously (the lamp is always on) for destruction of contaminants adsorbed on the catalyst surface and for extended lamp life
- It is recommended that the air handler be set to run continuously, except during periods of high humidity (more than 50%)
- If used in conjunction with an optional UV germicidal light, the following guidelines must be followed:
  - When a germicidal light is used with the PCO3 in direct line of sight, maintain a minimum distance of 6 ft. from the PCO3
  - If duct system has a 90° bend or turn in the duct between the PCO3 and germicidal light, a minimum distance of 3 ft. from the PCO3 should be maintained

**NOTE** - Refer to the Installation Instructions for additional information.

### COMPONENTS

- 1 MERV 16 Carbon Clean 16® Media Air Filter (1)**
  - Disposable pleated MERV 16 filter (Minimum Efficiency Reporting Value based on ASHRAE 52.2)
  - MERV (Minimum Efficiency Reporting Value) is a rating by ASHRAE that measures the removal of airborne contaminants
  - The MERV rating of a filter describes the size of the holes in the filter that allow air to pass through
  - The higher the MERV rating, the smaller the holes in the filter, providing enhanced filtration
  - The dirtier the filter, the better the filtration, however, the filters need to be replaced annually to prevent excess pressure drop and for maximum efficiency
  - More frequent filter changes may be required in situations with high dust or dirt loads
  - Particles and bioaerosols are captured on the filter
  - Recommended annual replacement

#### UVA Lamp / PureAir Cartridge

- 2 UVA Lamp (1)**
  - 55 watt florescent, low power consumption, UVA output
  - Recommended annual replacement
  - Lamp is packaged separately for field installation
  - Thumbscrews on lampholder allow quick and easy access for servicing

#### PureAir™ Cartridge

- Titanium dioxide coated
- Cartridge is packaged separately
- Recommended annual replacement

## FEATURES

### 4 Control Box Assembly

- Contains electrical power receptacle, electronic ballast with internal surge protector for UVA lamp
- Control box is hinged to allow easy access to the ballast and UVA Lamp / PureAir Cartridge for servicing

### CABINET

### 5 Pre-painted steel cabinet

- Multi-position
- PCO3-14-16 cabinet is sized for most Lennox air handler applications
- PCO3-16-16 and PCO3-20-16 cabinets are sized for most Lennox gas furnace applications
- See dimension drawing

### 6 Front panel is removable for service access

- Air flow direction may be reversed by rotating the unit top for bottom
- View port on front panel for verifying UVA lamp operation
- Three-prong, detachable 6-foot power cord for plug-in to 120V electrical connection
- Optional power cord for 230V operation is available and must be ordered separately

## SAFETY FEATURES

- Power cord must be completely removed from the front of the unit before the cover can be removed for servicing

## MAINTENANCE SUPPLIES - ORDER SEPARATELY

### Annual Maintenance Kit

- A maintenance kit is available for the PCO3-14-16, PCO3-16-16 and PCO3-20-16
- Each kit consists of:
  - Carbon Clean 16® (MERV 16) Media Air Filter (1)
  - Replacement UVA Lamp (1)
  - Replacement PureAir™ Cartridge(1)

### MERV 16 Carbon Clean 16® Media Air Filter

- Recommended annual replacement of the filter

## OPTIONAL ACCESSORIES - ORDER SEPARATELY

### Power Cord For 230 Volt Operation

- Six foot power cord with NEMA 620P male plug on one end and IEC 320 receptacle on other end
- Allows 230 volt operation without any additional modifications

## SPECIFICATIONS

	Model No.	PCO3-14-16	PCO3-16-16	PCO3-20-16
Nominal airflow capacity - cfm		1400	1600	2000
Pressure drop (new unit) - in. w.g.		0.25	0.31	0.31
Pressure drop (end of recommended life) - in. w.g.		0.42	0.42	0.42
Ethanol destruction rate - mg/min. (single pass rated flow destruction rate @ 500 µg/m <sup>3</sup> ethanol)		2.5	3.0	4.0
Operating Environment		0°F to 140°F outside of duct 10 to 60 percent relative humidity (Optimal performance at 50 percent relative humidity)		
Number of Lamps		1	1	1
Filter size - H x D x W - in.	Nominal	20 x 21 x 5	16 x 26 x 5	20 x 26 x 5
	Actual	20 x 20-5/8 x 4-3/8	16-3/8 x 25-1/2 x 4-3/8	20 x 25-1/2 x 4-3/8
Filter life		Up to 12 months	Up to 12 months	Up to 12 months
Shipping Weight - lbs.		27	25	27
Electrical Data		120V or <sup>1</sup> 230V - 1 phase - 60 hz (less than 1 amp)		
Power Consumption	120 Volt	58	58	58
	<sup>1</sup> 230 Volt	58	58	58

## MAINTENANCE SUPPLIES - ORDER SEPARATELY

		Y6616	Y6612	Y6608
<b>Annual Maintenance Kit</b> (includes 1 of each per kit)	Catalog Number (1-pack)	<b>Y6616</b>	<b>Y6612</b>	<b>Y6608</b>
	Catalog Number (4-pack)	<b>N/A</b>	<b>Y6614</b>	<b>Y6610</b>
MERV 16 Carbon Clean 16® Pleated Filter	Size - H x D x W - in.	20 x 21 x 5	16 x 26 x 5	20 x 26 x 5
UVA Lamp	Number of lamps	1	1	1
PureAir™ Cartridge	Size - H x D x W - in.	1-7/8 x 20 x 1	1-7/8 x 20 x 1	1-7/8 x 20 x 1
MERV 16 Carbon Clean 16® Pleated Filter	Catalog Number	<b>Y6606</b>	<b>Y6605</b>	<b>Y6604</b>
PureAir Cartridge	Catalog Number	<b>Y6621</b>	<b>Y6607</b>	<b>Y6607</b>

## OPTIONAL ACCESSORIES - ORDER SEPARATELY

	91X44	91X44	91X44
Power Cord for 230V Operation	<b>91X44</b>	<b>91X44</b>	<b>91X44</b>

<sup>1</sup> Optional 230V power cord is required and must be ordered separately.

## AIR RESISTANCE

Air Volume cfm	PCO3-14-16 in. w.g.	PCO3-16-16 in. w.g.	PCO3-20-16 in. w.g.
400	0.05	0.04	0.03
600	0.07	0.07	0.06
800	0.11	0.11	0.08
1000	0.15	0.15	0.11
1200	0.20	0.20	0.15
1400	0.25	0.25	0.18
1600	---	0.31	0.22
1800	---	---	0.27
2000	---	---	0.31

## MINIMUM FILTER EFFICIENCY

MERV Rating	<sup>1</sup> Filter Efficiency (percentage)		
	E1 (0.3 to 1.0 microns)	E2 (1.0 to 3.0 microns)	E3 (3.0 to 10.0 microns)
MERV 16	95%	99%	99%

<sup>1</sup> Values are based on lab tests conducted with conditions included in ASHRAE Standard 52.2.

## DIMENSIONS

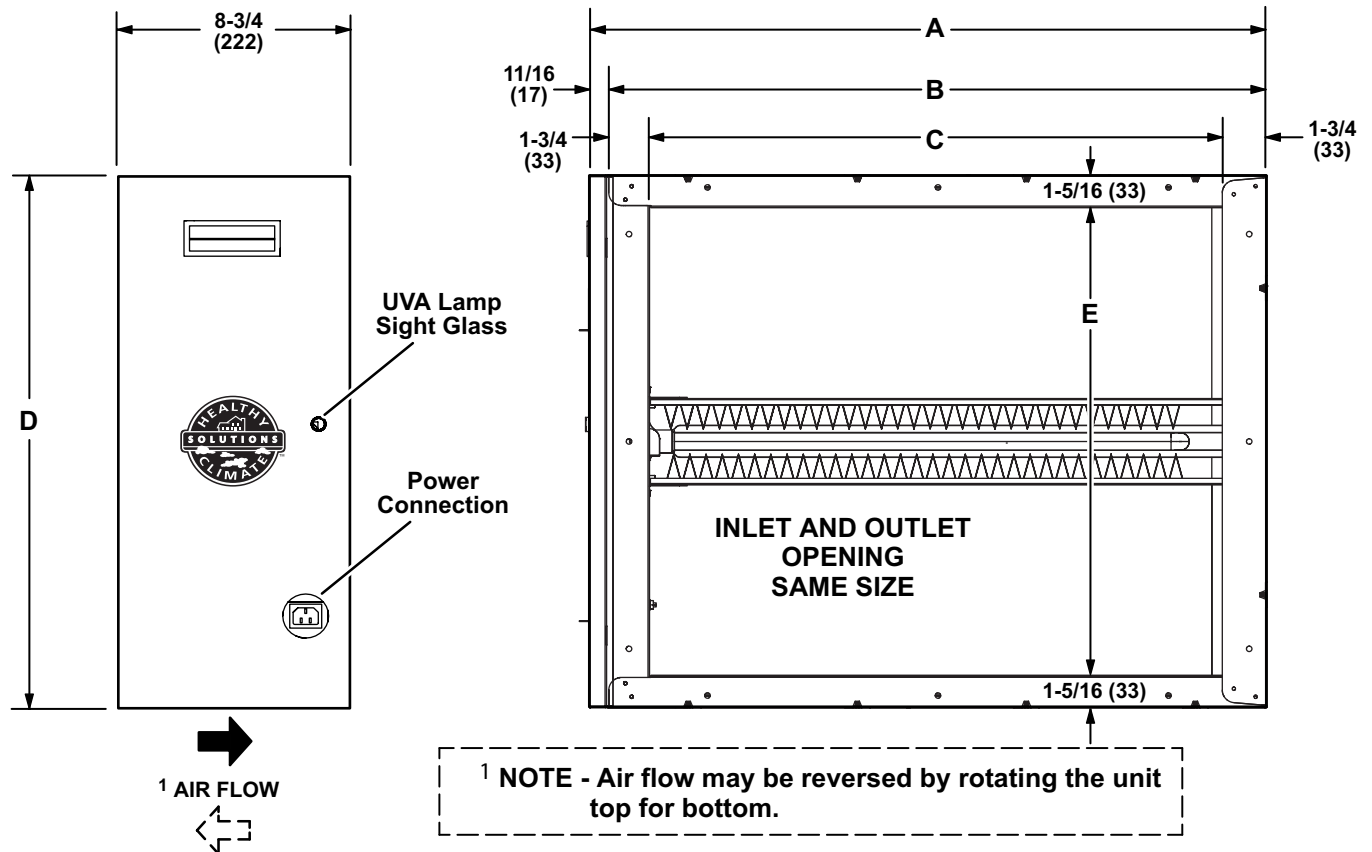

Model No.	A		B		C		D		E	
	inches	mm	inches	mm	inches	mm	inches	mm	inches	mm
PCO3-14-16	23-3/4	603	23	584	20-1/4	514	21-1/8	537	18-1/2	470
PCO3-16-16	26-1/2	673	25-3/4	654	23	584	17-1/2	445	14-5/8	371
PCO3-20-16	26-1/2	673	25-3/4	654	23	584	21-1/8	537	18-1/2	470

## CABINET MATCH-UPS - PCO3 WITH FURNACE / AIR HANDLER

ALSO SEE ILLUSTRATIONS ON NEXT PAGE FOR ADDITIONAL DETAILS

Furnaces	Filter Cabinet			Comment
	PCO3-14-16	PCO3-16-16	PCO3-20-16	
"A" Width Furnace with Side Return Air		•		No duct transition required.
"A" Width Furnace with Bottom Return Air		•		28-1/2" x 3" side seal strip or duct transition needed.
"B" Width Furnace with Side Return Air		•		No duct transition required.
"B" Width Furnace with Bottom Return Air		•		No duct transition required.
"C" Width Furnace with Side Return Air (up to 4 ton)		•	•	No duct transition required, for high system static application use PCO3-20-16.
"C" Width Furnace with Side Return Air (5 ton)			•	<b>Option 1</b> - No duct transition required, use Return Air Base ( <b>98M58</b> ). <b>Option 2</b> - Overcut top edge of side return opening by 1 in. to make opening 15 in. x 23 in. (H x W).
"C" Width Furnace with Bottom Return Air			•	No duct transition required.
"D" Width Furnace with Side Return Air			•	<b>Option 1</b> - No duct transition required, use Return Air Base ( <b>98M59</b> ). <b>Option 2</b> - Overcut top edge of side return opening by 1 in. to make opening 15 in. x 23 in. (H x W).
"D" Width Furnace with Bottom Return Air			•	26-1/2" x 3 1/2" side seal strip or duct transition needed.
Air Handlers	PCO3-14-16	PCO3-16-16	PCO3-20-16	Comment
Air Handler (W x D) - 18-1/2 x 22 in. CBA25UH(V)-018-024-030	•			22 x 2 in. side seal strip or duct transition needed.
Air Handler (W x D) - 21-1/2 x 22 in. CBA25UH(V)-036-042-048-060	•			No duct transition required.
Air Handler (W x D) - 21-1/4 x 20-5/8" CBA27UHE-018 CBA27UHE-024 CBA38MV-018/024	•			No duct transition required.
Air Handler (W x D) - 21-1/4 x 22-5/8" CBA27UHE-030 CBA27UHE-036 CBA38MV-030-036	•			No duct transition required.
Air Handler (W x D) - 21-1/4 x 24-5/8" CBA27UHE-042 CBA27UHE-048 CBA27UHE-060 CBA38MV-042-048-060			•	21" x 3" side seal strip or duct transition needed.

# CABINET MATCH-UPS - PCO3 WITH FURNACE / AIR HANDLER

## UPFLOW FURNACE/AIR HANDLER (Bottom Return Air)

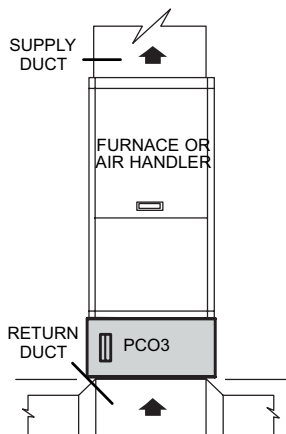

## UPFLOW FURNACE (Side Return Air - up to 4 ton)

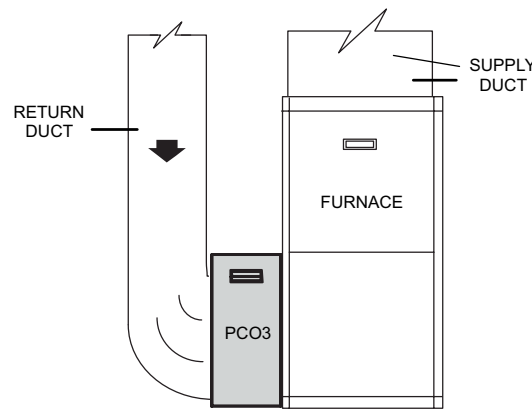

## DOWNFLOW FURNACE/AIR HANDLER

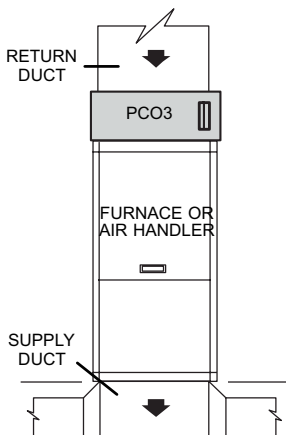

## UPFLOW FURNACE (Option 1 - Side Return Air - 5 ton) (With Optional RAB Return Air Base)

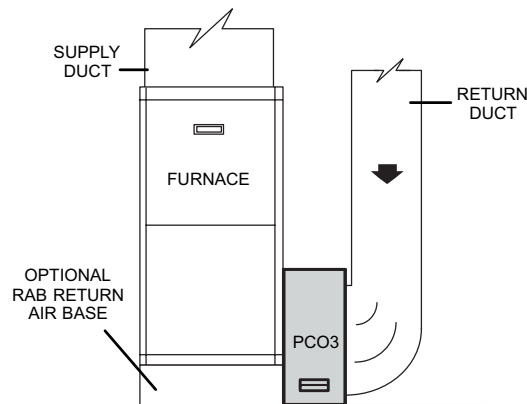

## HORIZONTAL FURNACE/AIR HANDLER

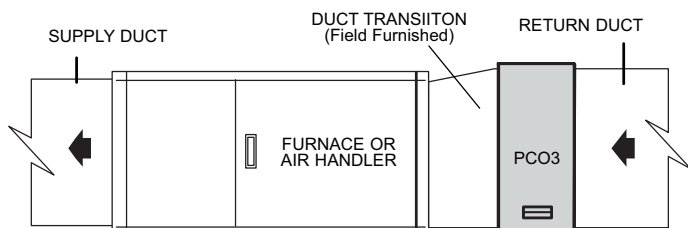

## UPFLOW FURNACE (Option 2 - Side Return Air - 5 ton) (Modified Return Air Opening)

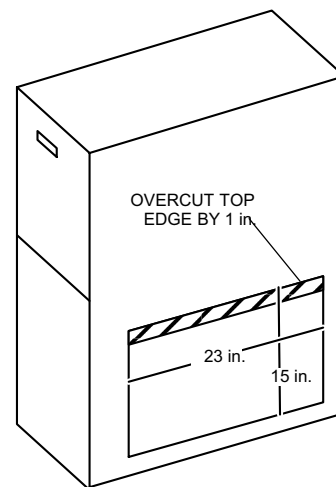

## REVISIONS

Sections	Description of Change
Optional Accessories	4-Pack Maintenance Kit for PCO3-14-16 discontinued.



Visit us at [www.Lennox.com](http://www.Lennox.com)

For the latest technical information, [www.LennoxPros.com](http://www.LennoxPros.com)

Contact us at 1-800-9-LENNOX

NOTE - Due to Lennox' ongoing commitment to quality, Specifications, Ratings and Dimensions subject to change without notice and without incurring liability. Improper installation, adjustment, alteration, service or maintenance can cause property damage or personal injury. Installation and service must be performed by a qualified installer and servicing agency.

©2023 Lennox Industries, Inc.